

ally

Vol. 01

2020furnituredesign.co.uk

ally

Ally is a modular seating system designed to shape collaborative spaces with softness, flexibility and architectural simplicity. Defined by flowing curves and layered forms, it creates welcoming environments that support interaction, focus and wellbeing.

Minimal form.
Maximum adaptability.

Designed by 2020FD.



Crafted with care. Designed for people.

Ally is a modular seating collection created to bring comfort, flexibility and contemporary character into modern workspaces. Defined by sculptural curves, layered backrests and soft architectural forms, the system transforms breakout areas, reception spaces and collaborative zones into welcoming environments that encourage interaction and connection.

Designed around the principles of neurodesign and workplace wellbeing, Ally supports focus, comfort and acoustic balance while creating a

calm and intuitive atmosphere. Its modular nature allows endless configurations that evolve effortlessly with changing spatial needs and team dynamics.

Integrated power and USB options support modern ways of working without compromising the clean and refined aesthetic of the collection. Crafted with precision and timeless simplicity, Ally combines functionality, versatility and sophisticated design in one cohesive seating system.

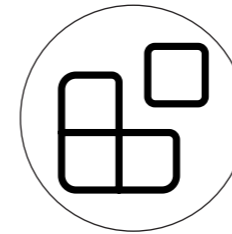

Easily adapts to different layouts and project needs.

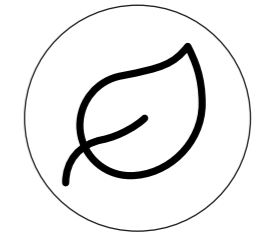

Responsibly sourced materials with a focus on durability.

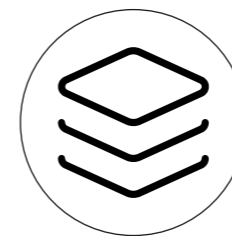

Available in three different height options: backrest, mid extension and upper extension.

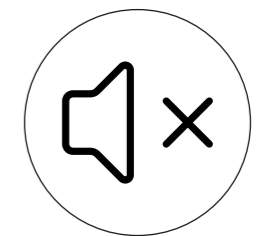

Booths designed to reduce noise and support focused meetings and collaboration.



ally

Modular. Flexible. Soft.



Manifest

Work evolves. Modern workplaces need spaces that adapt effortlessly to changing ways of collaborating, focusing and connecting. Ally is designed to move with these dynamics — never against them.

Comfort matters. Soft curves, layered backrests and generous proportions create welcoming environments that encourage interaction while supporting relaxation and wellbeing throughout the day.

Flexibility is essential. Modular configurations allow Ally to shape breakout areas, reception spaces and collaborative zones with ease, adapting to both intimate and large-scale environments.

Design should feel human. Calm forms, tactile materials and balanced proportions create a softer architectural language that supports focus, acoustic comfort and a more intuitive workplace experience.

Technology integrates naturally. Optional power and USB connectivity support contemporary ways of working while maintaining the clean and refined aesthetic of the collection.

Furniture should evolve with people. Ally is designed to create spaces that feel open, adaptable and connected — bringing together functionality, comfort and timeless contemporary design.

ally

Booths

Alongside the modular seating collection, Ally is also available as a range of straight booth solutions designed for focused work, informal meetings and collaborative spaces. Available in configurations for 2, 4 and 6 people, the booths create comfortable semi-private environments that support both concentration and interaction.

Each booth can be equipped with integrated tables, power sockets, USB charging and media connectivity, making them ideal for contemporary workplaces, hybrid meetings and everyday collaboration.

Defined by soft architectural lines and a calm visual presence, Ally Booths combine comfort, functionality and acoustic support within one cohesive workspace system.



Why Modular?

Modular

Workspaces constantly evolve, and Ally is designed to evolve with them. Its modular system allows spaces to be reshaped easily for collaboration, waiting areas, informal meetings or quiet breakout zones.

The collection's curved geometry creates fluid layouts that feel open, balanced and adaptable while maintaining a calm architectural presence within the interior. Each module can work independently or as part of a larger composition, supporting long-term flexibility without compromising visual consistency.

Ally combines refined simplicity, adaptability and contemporary functionality in one cohesive seating system.



Collection

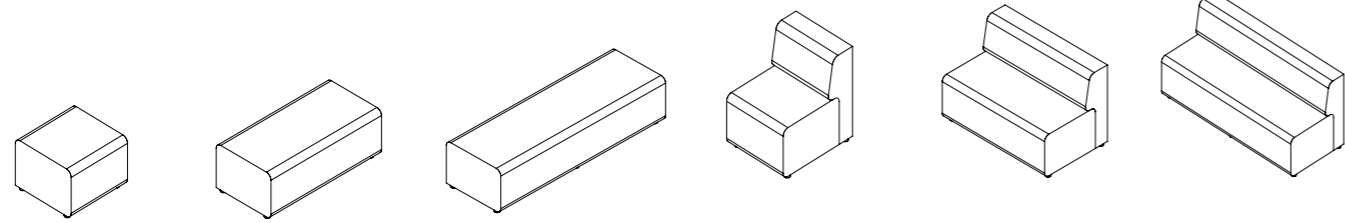

ALL01	ALL02	ALL03	ALL04	ALL05	ALL06
W 600 D 595 H 450	W 1200 D 595 H 450	W 1800 D 595 H 450	W 600 D 735 H 800	W 1200 D 735 H 800	W 1800 D 735 H 800

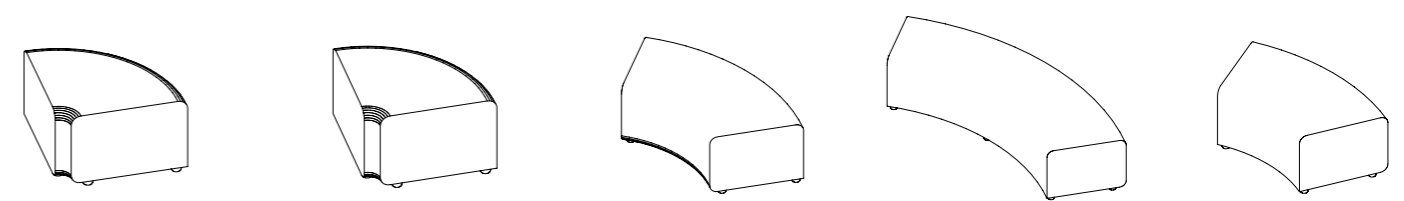

ALL19 90 DEG W 660 D 660 H 450	ALL20 90 DEG W 800 D 800 H 450	ALL21 60 DEG W 1180 D 595 H 450	ALL22 60 DEG W 2235 D 595 H 450	ALL23 45 DEG W 1175 D 595 H 450
--	--	---	---	---

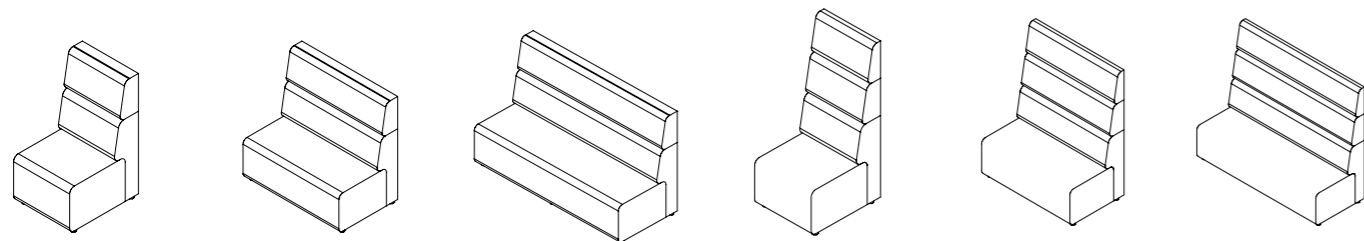

ALL07	ALL08	ALL09	ALL10	ALL11	ALL12
W 600 D 735 H 1150	W 1200 D 735 H 1150	W 1800 D 735 H 1150	W 600 D 735 H 1500	W 1200 D 735 H 1500	W 1800 D 735 H 1500

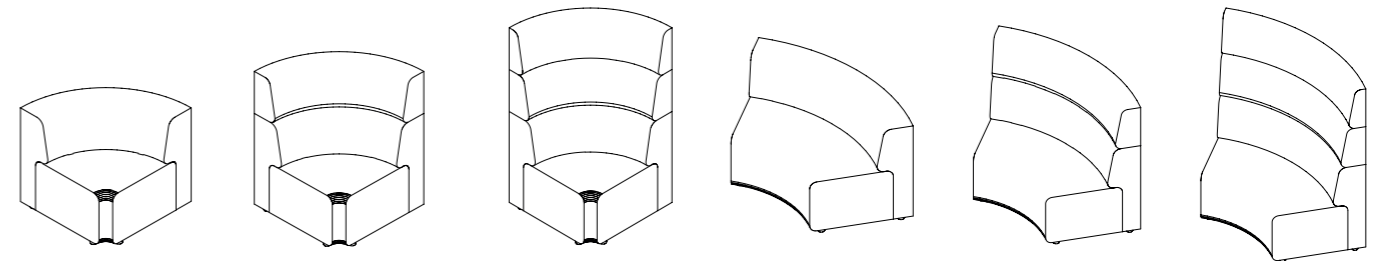

ALL24 90 DEG W 800 D 800 H 800	ALL25 90 DEG W 800 D 800 H 1150	ALL26 90 DEG W 800 D 800 H 1500	ALL27 60 DEG W 1500 D 735 H 800	ALL28 60 DEG W 1500 D 735 H 1150	ALL29 60 DEG W 1500 D 735 H 1500
--	---	---	---	--	--

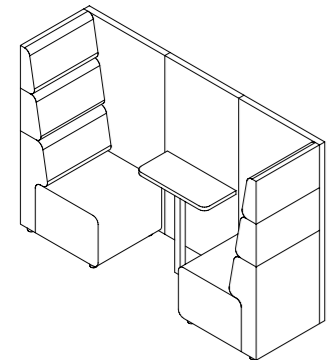

ALL13
W 2230
D 650
H 1500

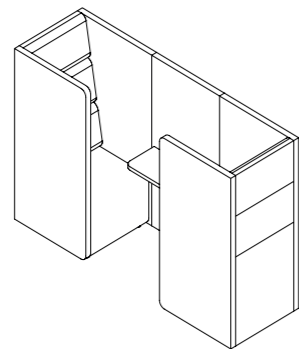

ALL14
W 2230
D 700
H 1500

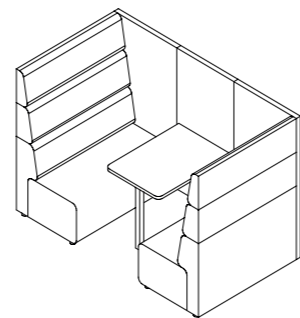

ALL15
W 2230
D 1250
H 1500

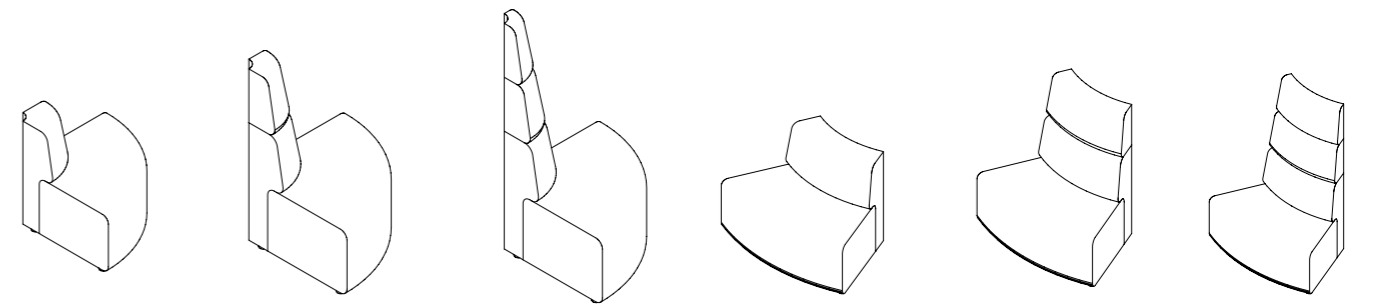

ALL30 90 DEG W 800 D 800 H 800	ALL31 90 DEG W 800 D 800 H 1150	ALL32 90 DEG W 800 D 800 H 1500	ALL33 60 DEG W 1500 D 735 H 800	ALL34 60 DEG W 1500 D 735 H 1150	ALL35 60 DEG W 1500 D 735 H 1500
--	---	---	---	--	--

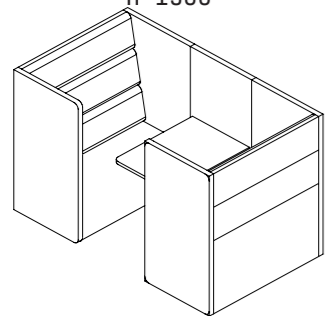

ALL16
W 2230
D 1300
H 1500

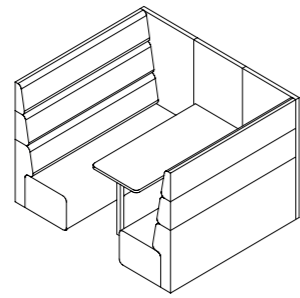

ALL17
W 2230
D 1850
H 1500

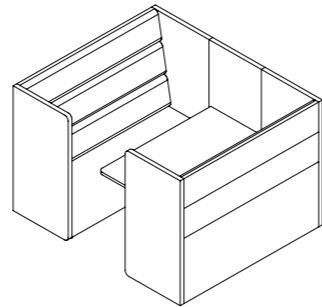

ALL18
W 2230
D 1900
H 1500

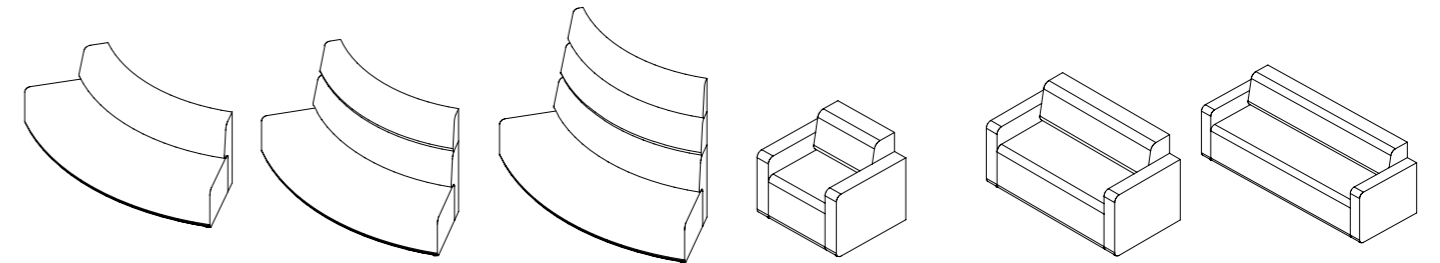

ALL36 60 DEG W 2235 D 735 H 800	ALL37 60 DEG W 2235 D 735 H 1150	ALL38 60 DEG W 2235 D 735 H 1500	ALL39 W 840 D 735 H 800	ALL40 W 1440 D 735 H 800	ALL41 W 2040 D 735 H 800
---	--	--	----------------------------------	-----------------------------------	-----------------------------------

ally

Tables



ally



Tables

Tables designed for Ally are created as a natural extension of the collection's modular and collaborative character. With clean forms, refined detailing and durable construction, they integrate seamlessly into breakout spaces, meeting areas and contemporary workplace environments.

To support modern ways of working, tables can be configured with integrated features including:

- 230V power sockets
- USB charging ports
- HDMI and RJ45 connectivity
- Integrated cable management

For larger configurations such as Ally 13–18, optional TV brackets and media integration can also be incorporated, creating connected spaces for collaboration and hybrid meetings.

Designed to balance functionality with timeless contemporary aesthetics, Ally tables bring flexibility, technology and visual consistency into one cohesive system.



Fabric & Materials

Upholstery finishes

band 1

Camira era
44 colours available

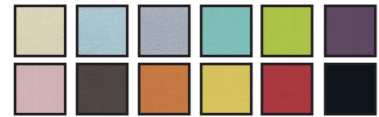

Camira rivet
33 colours available



Camira vita (vinyl)
51 colours available



Camira cara
32 colours available



Camira lucia
17 colours available



Camira sonus
17 colours available

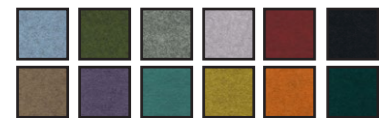

band 2

Camira blazer
77 colours available



Camira hemp
21 colours available

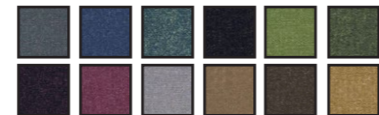

Panaz highland
37 colours available



screen fabrics

Camira blazer lite
42 colours available



Camira synergy 170
24 colours available



for special request

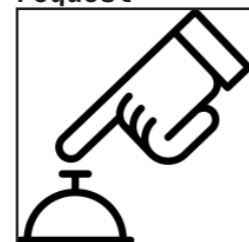

Other fabric options are available upon request - please us for details.

band 2

Camira synergy
75 colours available



Camira silk
19 colours available



Panaz highland stretch
23 colours available



Camira mainline flax
57 colours available

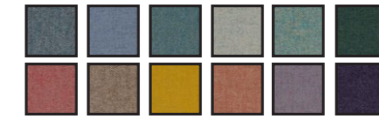

Camira track
18 colours available



Panaz zest (vinyl)
60 colours available

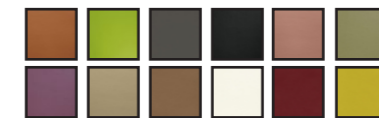

Camira 24/7
16 colours available



Camira mainline plus
17 colours available



Panaz aston (vinyl)
100 colours available



Choose your own

Our upholstery collection is structured to provide clarity and flexibility in material selection. Fabrics are divided into two categories: Band 1 and Band 2, allowing projects to meet both aesthetic and performance requirements.

Band 1 offers a versatile range of high-quality fabrics that balance durability, functionality, and visual appeal. These materials deliver reliable performance with a refined finish.

Band 2 features a selection of premium textiles with richer textures, enhanced tactility, and expanded color options-ideal for more sophisticated interiors.

The collection also includes screen fabrics for vertical applications such as acoustic panels and privacy screens, ensuring both performance and visual consistency.

Selected finishes are available in vinyl, offering resistance to moisture, staining, and intensive use-ideal for high-traffic environments requiring easy maintenance without compromising design quality.

Fabric & Materials

MFC finishes

egger white
W1000

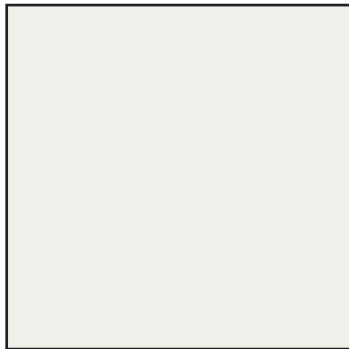

egger light grey
u708



kronospan stone grey
0112

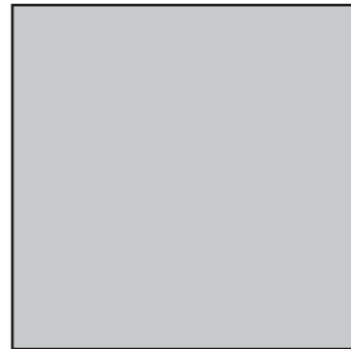

egger dust
grey u732



kronospan
anthracite 0164



kronospan black
0190

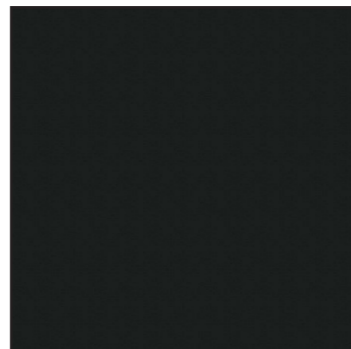

kronospan
maple 0375



for special
request

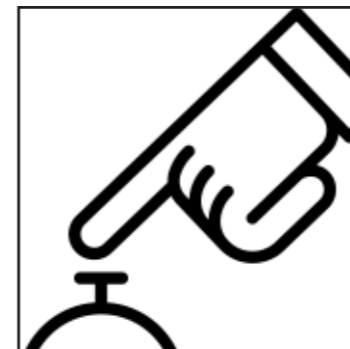

kronospan fine oak
8431



egger willow beech
h1910



egger dijon
walnut H3734

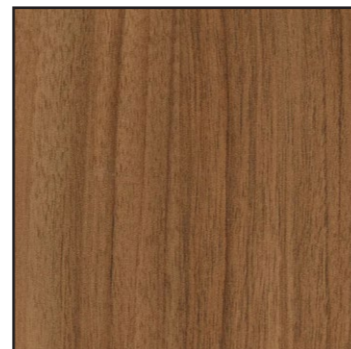

Our products are built using carefully selected materials that combine visual quality with functional performance. We utilize MFC boards along with layered, sound-absorbing structures and soft textile finishes to help reduce unwanted sound reflections from surrounding surfaces such as walls, furniture, and glazing.

The material composition is designed to support speech clarity and everyday comfort, minimizing background noise and improving the overall acoustic experience of the space.

Choose your own

You can choose from a wide range of finishes and material options to match your project's character and design direction. We use a selection of high-quality MFC boards from trusted suppliers, ensuring durability, consistency, and a refined appearance across all elements.

In addition to the standard finishes, custom materials and colors can be provided upon request. For larger or more specific projects, we are able to source and prepare tailored solutions based on the client's needs and preferred aesthetics.

Fabric & Materials

MFC finishes

egger white
W1000

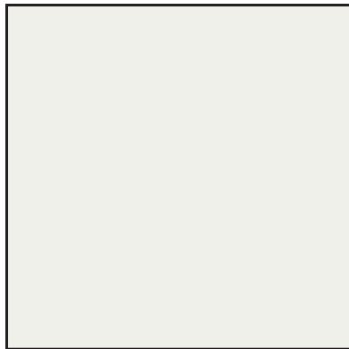

egger light grey
u708



kronospan stone grey
0112

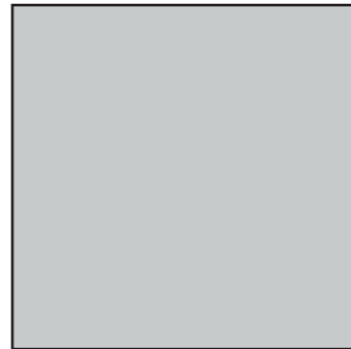

egger dust
grey u732



kronospan
anthracite 0164



kronospan black
0190

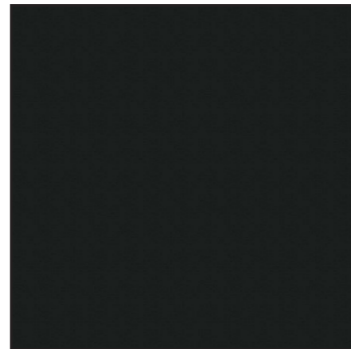

kronospan
maple 0375



for special
request

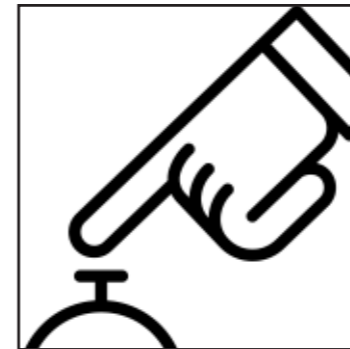

kronospan fine oak
8431



egger willow beech
h1910



egger dijon
walnut H3734



Our products are built using carefully selected materials that combine visual quality with functional performance. We utilize MFC boards along with layered, sound-absorbing structures and soft textile finishes to help reduce unwanted sound reflections from surrounding surfaces such as walls, furniture, and glazing.

The material composition is designed to support speech clarity and everyday comfort, minimizing background noise and improving the overall acoustic experience of the space.

Choose your own

You can choose from a wide range of finishes and material options to match your project's character and design direction. We use a selection of high-quality MFC boards from trusted suppliers, ensuring durability, consistency, and a refined appearance across all elements.

In addition to the standard finishes, custom materials and colors can be provided upon request. For larger or more specific projects, we are able to source and prepare tailored solutions based on the client's needs and preferred aesthetics.

Fabric & Materials

MFC finishes

egger white
W1000

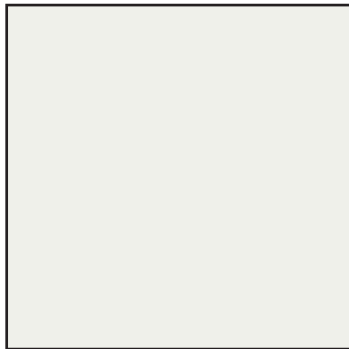

egger light grey
u708



kronospan stone grey
0112

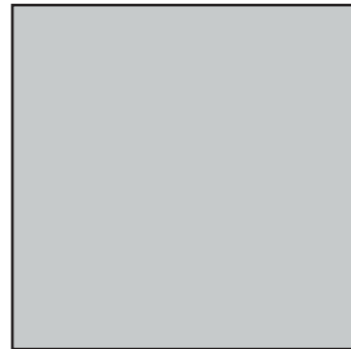

egger dust
grey u732



kronospan
anthracite 0164



kronospan black
0190

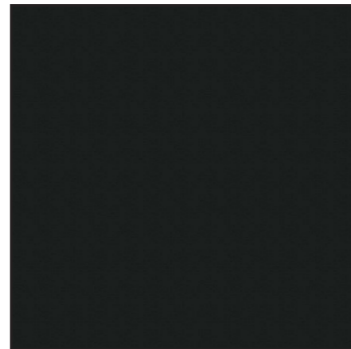

kronospan
maple 0375



for special
request

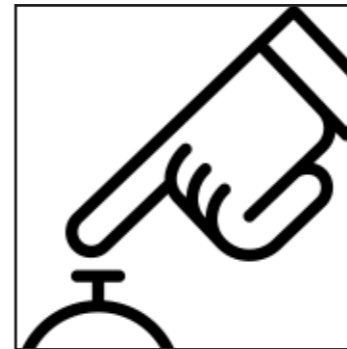

kronospan fine oak
8431



egger willow beech
h1910



egger dijon
walnut H3734



Our products are built using carefully selected materials that combine visual quality with functional performance. We utilize MFC boards along with layered, sound-absorbing structures and soft textile finishes to help reduce unwanted sound reflections from surrounding surfaces such as walls, furniture, and glazing.

The material composition is designed to support speech clarity and everyday comfort, minimizing background noise and improving the overall acoustic experience of the space.

Choose your own

You can choose from a wide range of finishes and material options to match your project's character and design direction. We use a selection of high-quality MFC boards from trusted suppliers, ensuring durability, consistency, and a refined appearance across all elements.

In addition to the standard finishes, custom materials and colors can be provided upon request. For larger or more specific projects, we are able to source and prepare tailored solutions based on the client's needs and preferred aesthetics.

Before you order

General

- By placing an order with 2020 Furniture Design, you agree to our standard Terms & Conditions, available on request or via our website.
- All prices are quoted in GBP and exclude VAT unless otherwise stated.

Delivery & Lead Times

- Pricing excludes delivery and installation unless specified within the quotation.
- Standard lead time for products within our RRP collection is approximately 4–6 weeks, subject to availability and seasonal demand.
- Bespoke products and customised finishes may require extended lead times depending on specification and project scope.
- During peak periods, including summer months, lead times may vary. Please contact your account manager for current production schedules.
- If shorter lead times are required, please speak with your account manager to discuss available options.

Delivery & Installations

- Installation services are available upon request and are quoted separately for each project.
- Where installation is carried out by 2020 Furniture Design, clear and unrestricted site access must be provided prior to the agreed installation date.
- Any preparatory works, including electrical works, site clearance or building works, remain the responsibility of the client. Delays or incomplete preparation may result in additional charges.
- Selected collections and bespoke projects must be delivered and installed exclusively by the 2020 Furniture Design installation team.

Warranty

- All products are covered by a 5-year warranty under normal fair wear and tear conditions.
- This warranty covers structural frames, foam and padding materials.
- Fabrics are covered under the respective manufacturer's warranty, typically 5 years depending on fabric selection.
- Electrical components, power modules and integrated charging solutions are covered by a 1-year warranty.
- Moving components and consumable parts, including hinges and door mechanisms, are covered by a 1-year warranty.
- Expected product lifecycle is approximately 15 years under normal commercial use conditions.

Care & Maintenance

To preserve the appearance and longevity of the product, regular maintenance and appropriate cleaning methods are recommended.

- Vacuum upholstery regularly to remove dust and dirt
- Clean spills immediately to prevent staining
- Avoid abrasive cleaners and harsh chemicals
- Use a soft damp cloth for laminate and hard surfaces
- Professional upholstery cleaning is recommended periodically

ally

Contact

☎ 07398 891127

✉ sales@2020furnituredesign.co.uk

🌐 2020furnituredesign.co.uk

📷 [@2020furnituredesign](https://www.instagram.com/2020furnituredesign)

2020[®]
FURNITURE DESIGN

Specialists
in breakout
spaces

Vol. 01

2020furnituredesign.co.uk