

N - ALLY

TAKE A BREAK

FROM THE

NORM

CRAFTSMANSHIP AND ENGINEERING ARE AT OUR HEART. WE MAKE THINGS THAT WORK, AND MANUFACTURE INTERESTING AND ENGAGING SOLUTIONS FOR EVERY BREAKOUT SPACE.

We are design led, blending function with form in a creative and stylish way. Our processes ensure consistency, and our innovative use of the latest CNC technology, ensures quality and reliability. We have been doing this for a long time, with an established team of craftsmen. We know how to design and manufacture, quality soft seating products. Value for money products that bring spaces to life. We lead the way in understanding the breakout and collaborative working space, and work with our dealer partners to bring spaces to life.

We are 2020 Furniture, we are break from the norm.





# N-ALLY

Whether you are looking to create some landscape seating, a meeting booth, acoustic screens, a breakout seating area or a statement flowing piece then N-Ally does it all. Available in both curved and straight formats, with low, mid and high

backs with a laminated or upholstered finish with the option of A/C and USB ports.





















# SPECIALISTS IN BREAKOUT SPACES





# N - NOLLY

























# N-ALLY

**NAL 01**

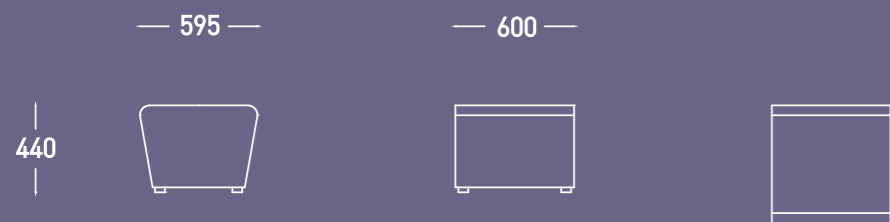

**NAL 02**

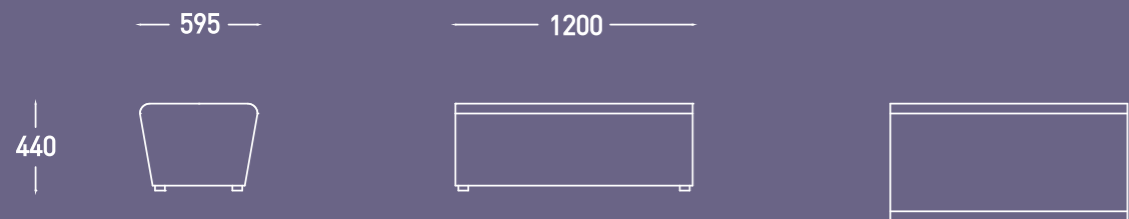

**NAL 03**

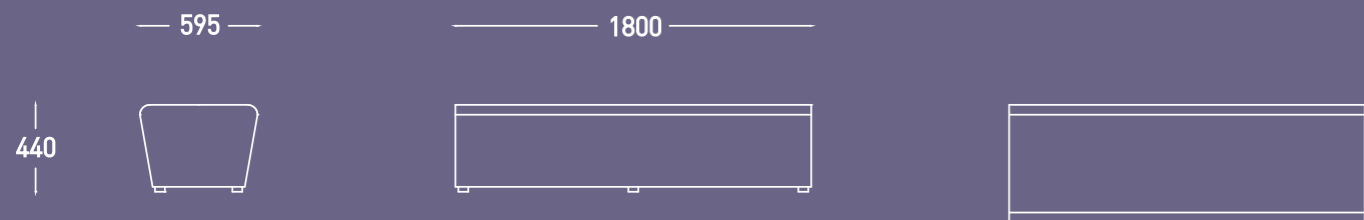

**NAL 04**

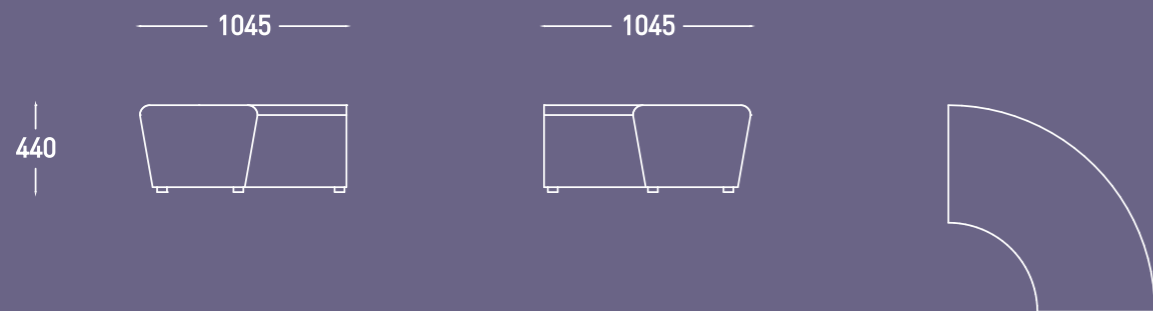

# N-ALLY

**N-ALLY 05**



**NAL 06**

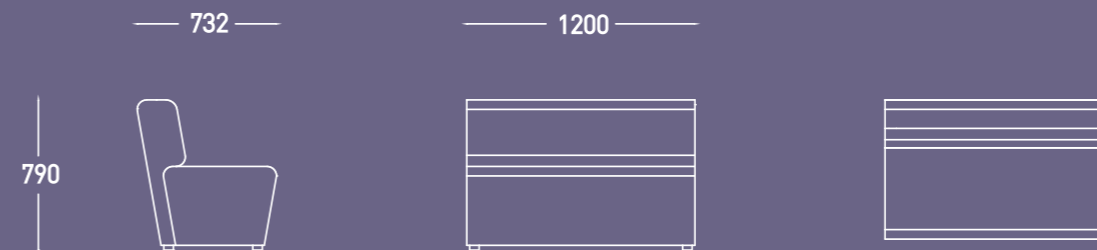

**NAL 07**

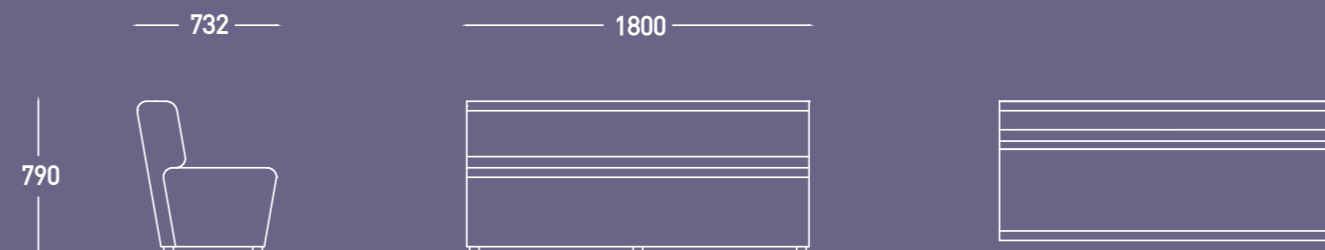

**NAL 08**

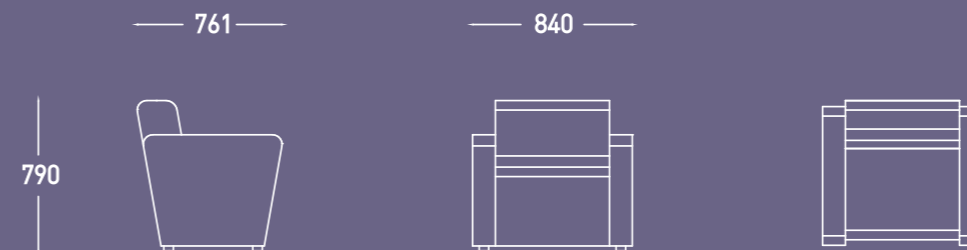



# N-ALLY

NAL 09

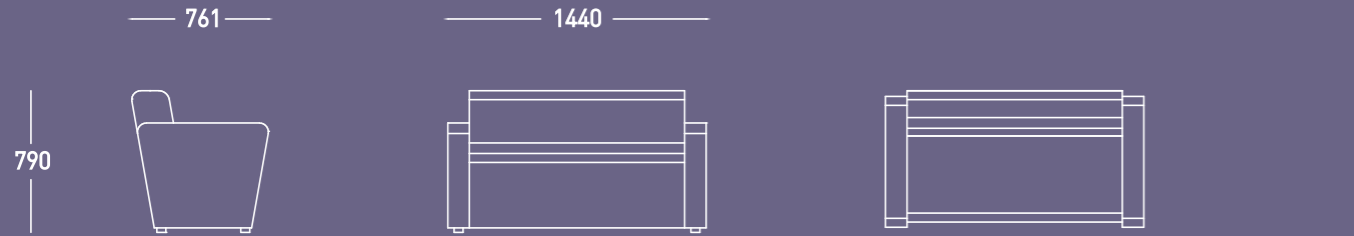

NAL 10

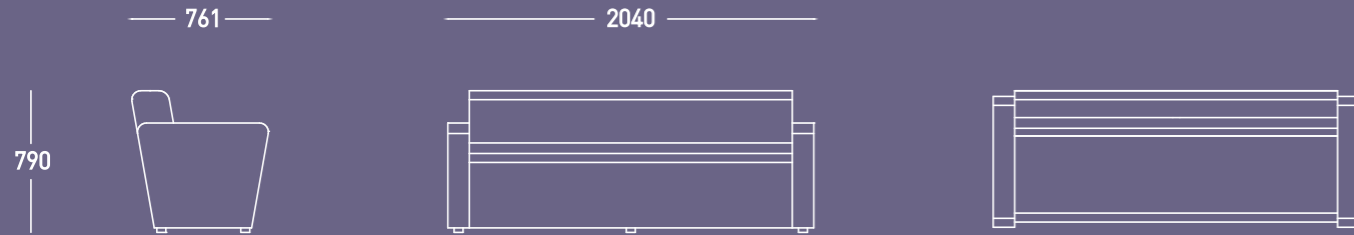

NAL 11



# N-ALLY

NAL 12

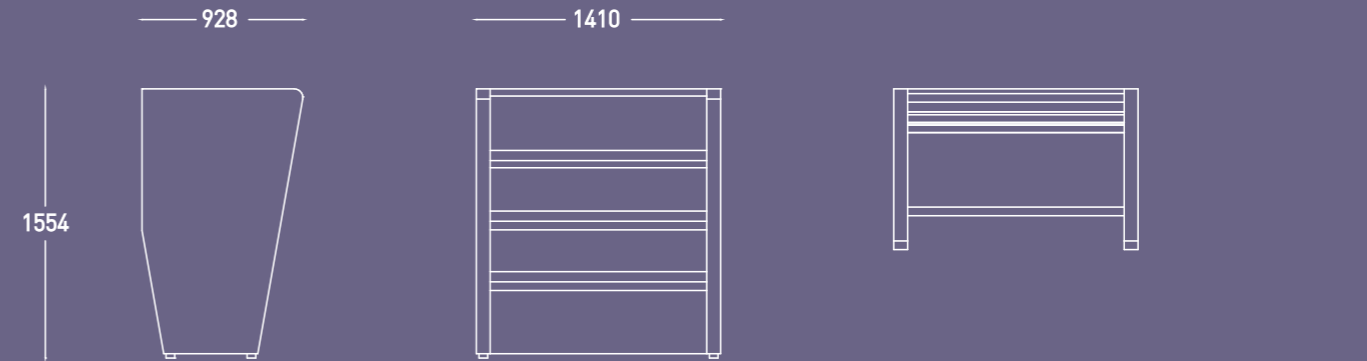

NAL 13

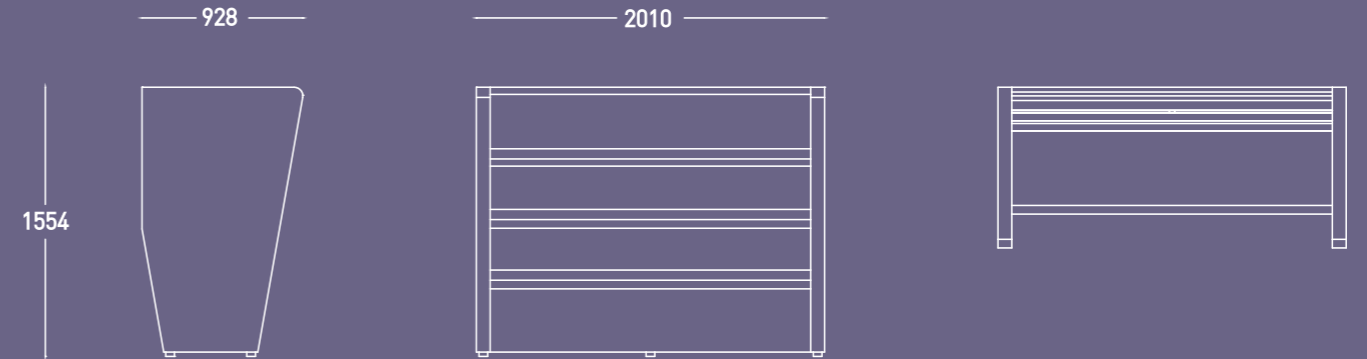

NAL 14





### N-ALLY

NAL 15

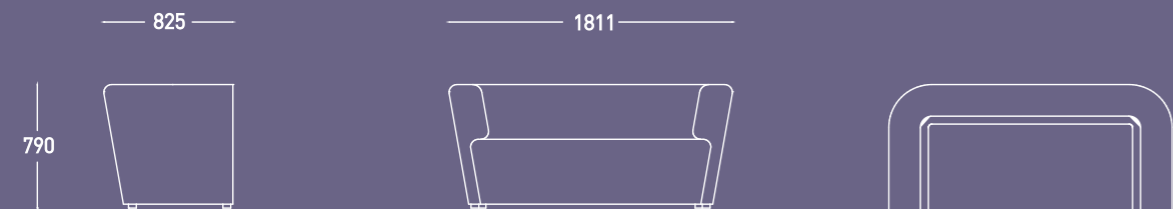

NAL 16

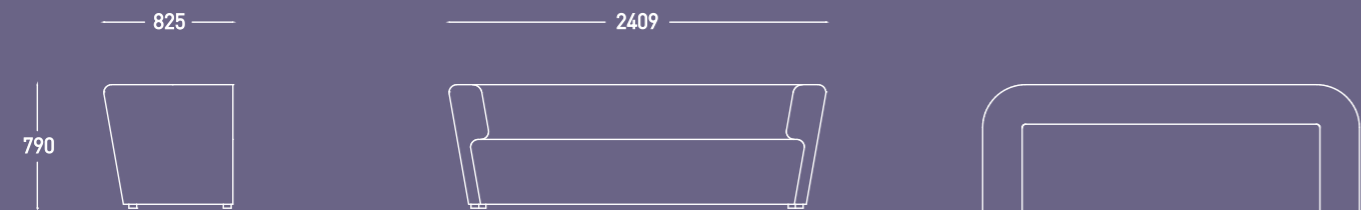

NAL 17

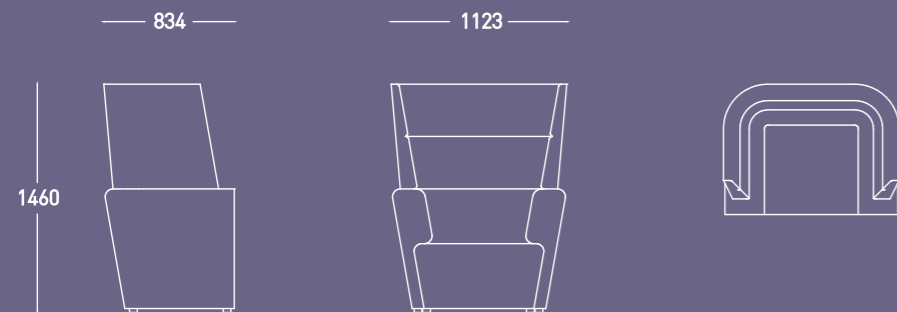

### N-ALLY

NAL 18

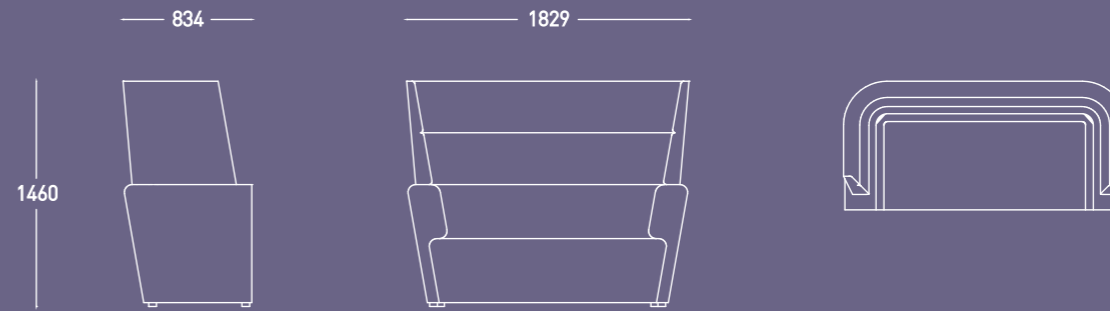

NAL 19

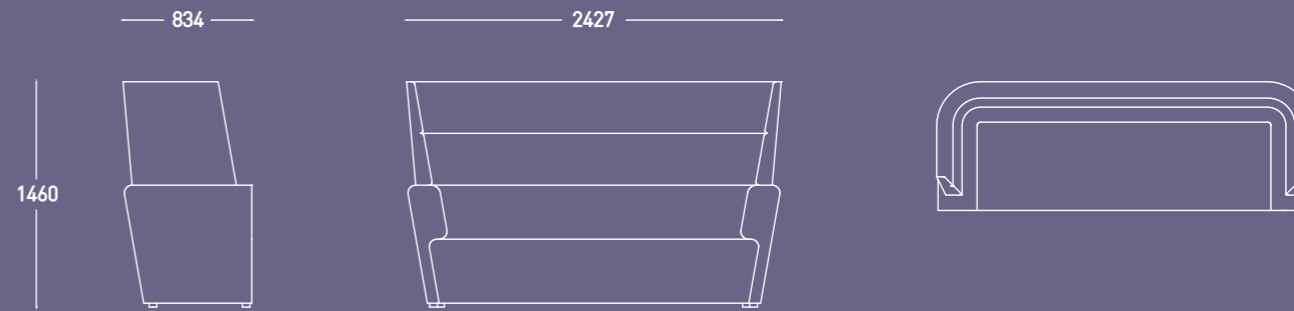

NAL 20

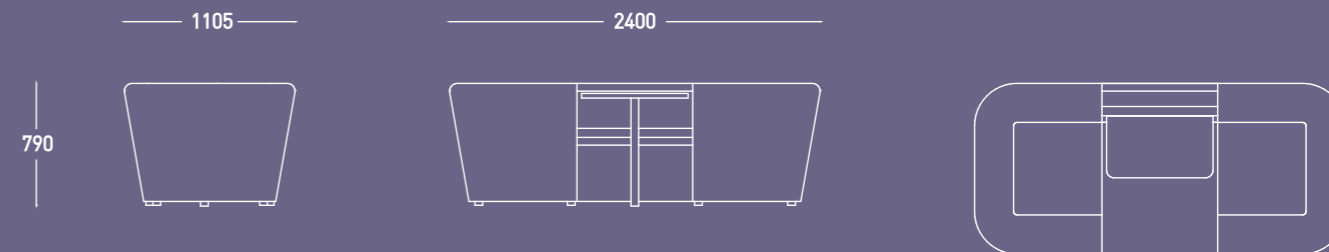



## N-ALLY

NAL 21

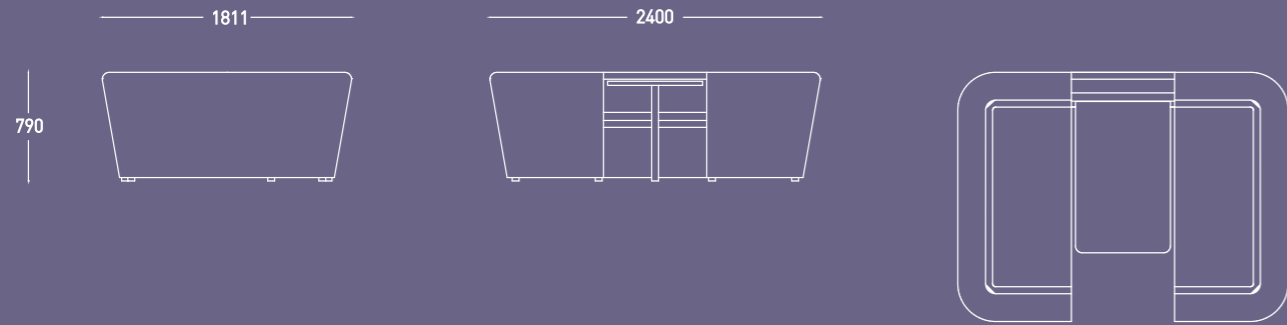

NAL 22

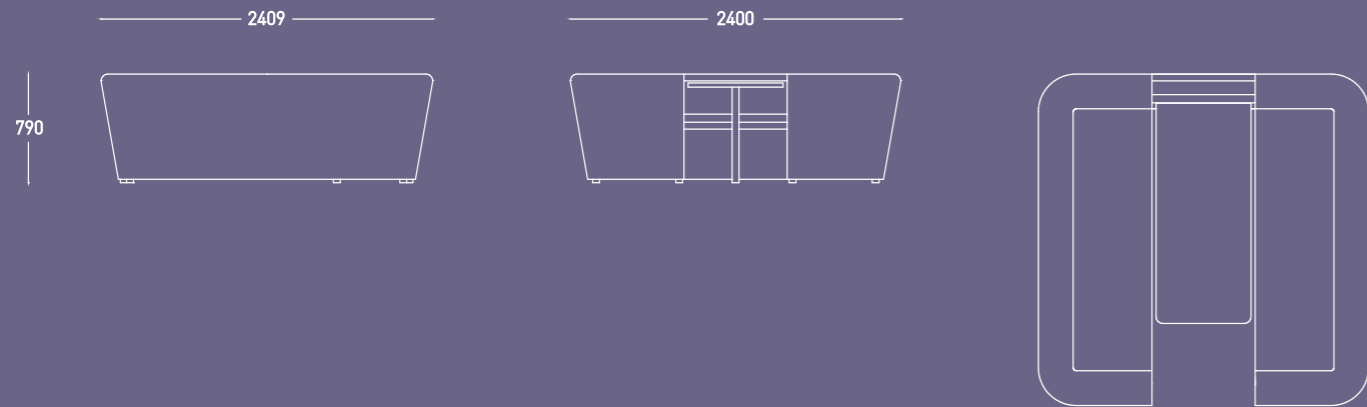

## N-ALLY

NAL 23

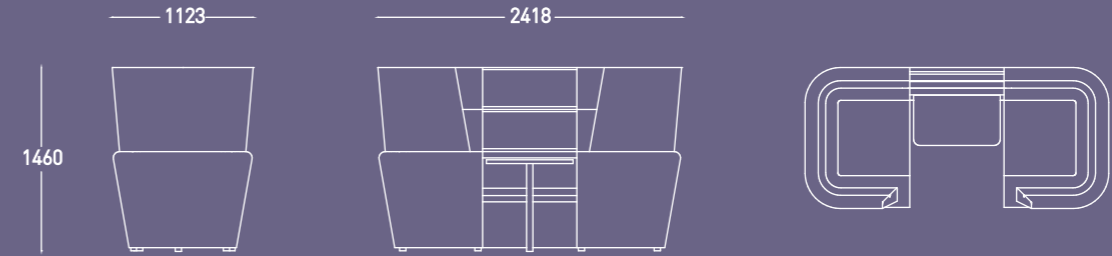

NAL 24

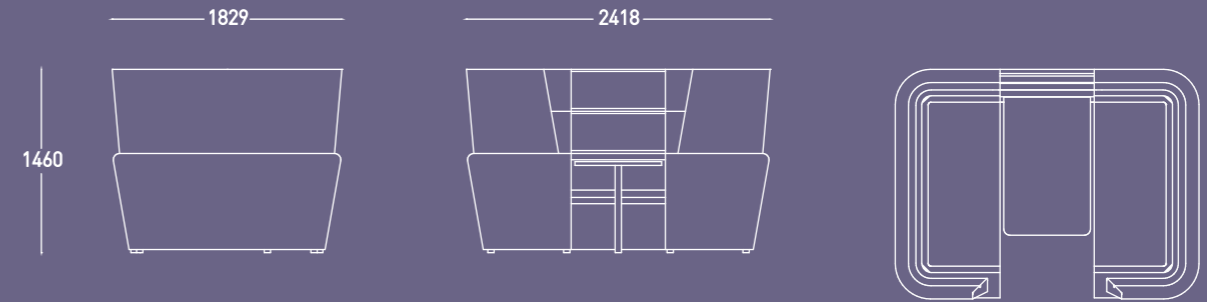

NAL 25

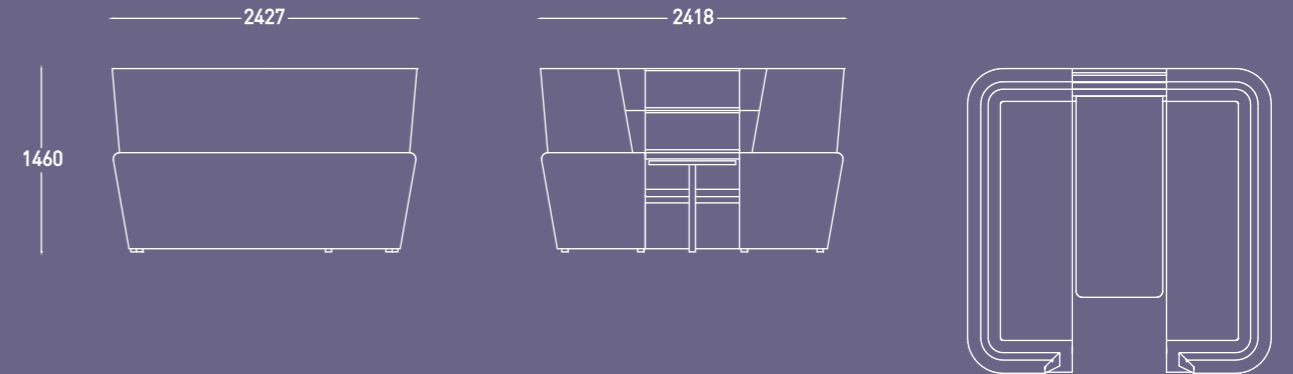



# N-ALLY

NAL 26

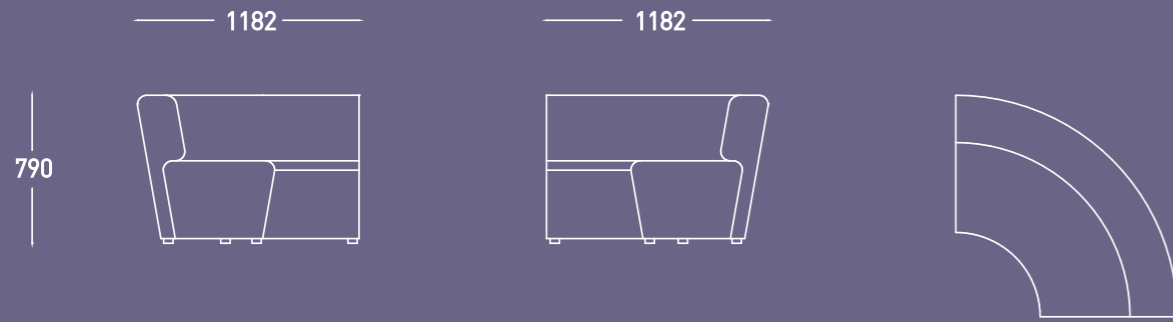

NAL 27

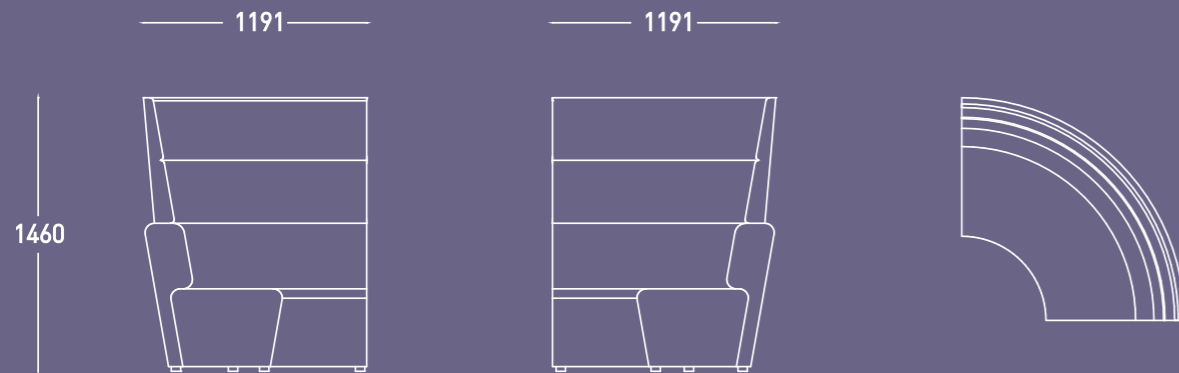

NAL 28

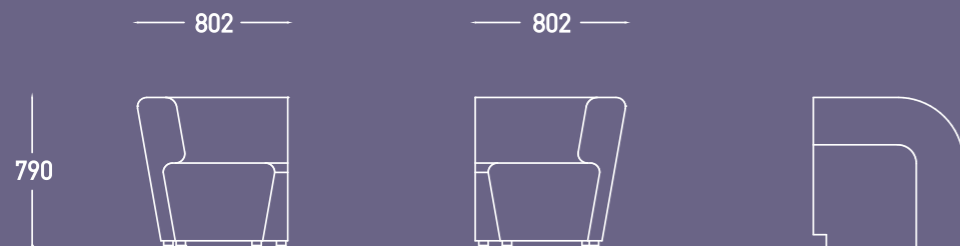

# N-ALLY

NAL 23

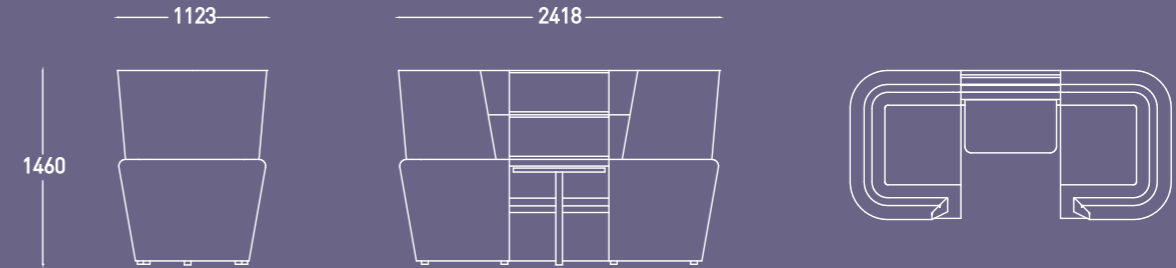

NAL 24

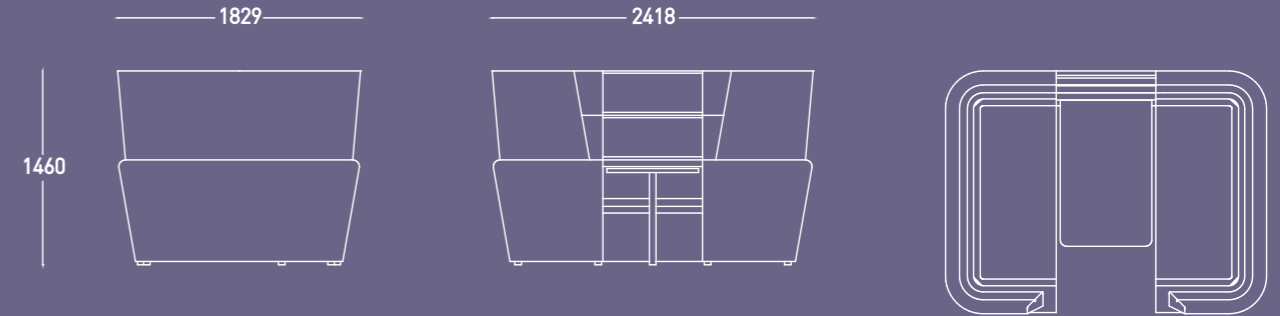

NAL 25

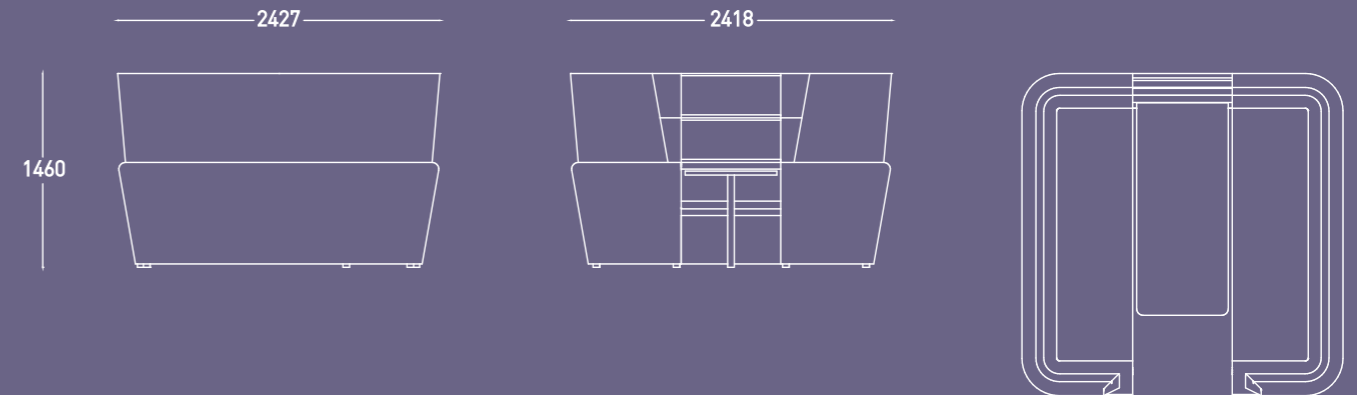



# N-ALLY

**NAL 26**

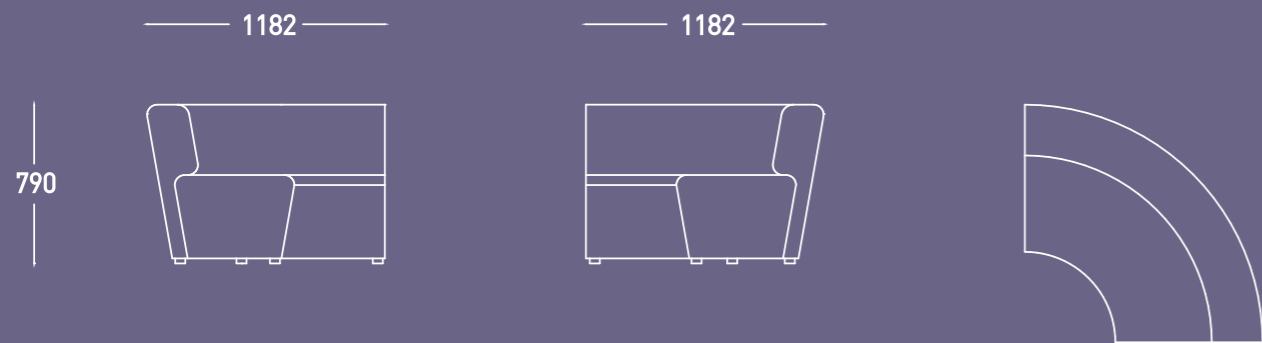

**NAL 27**

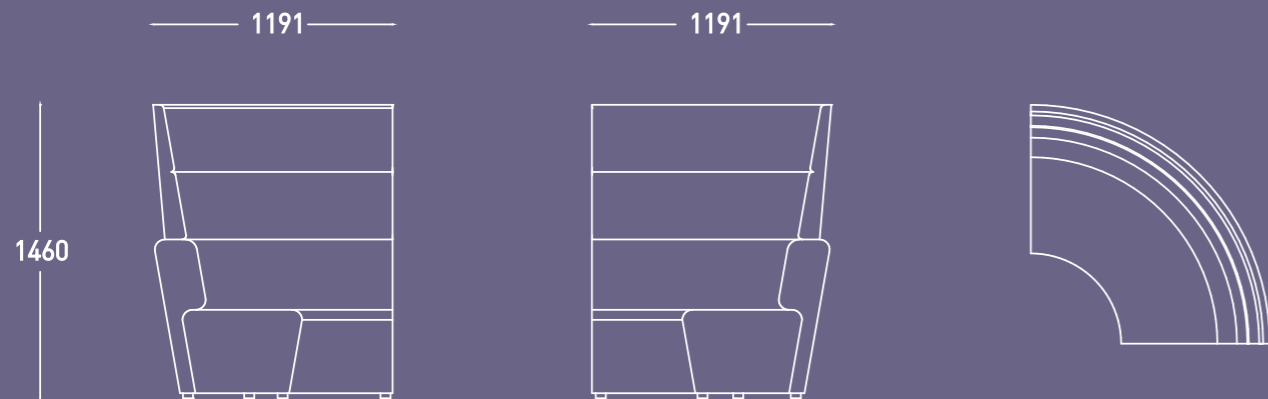

**NAL 28**

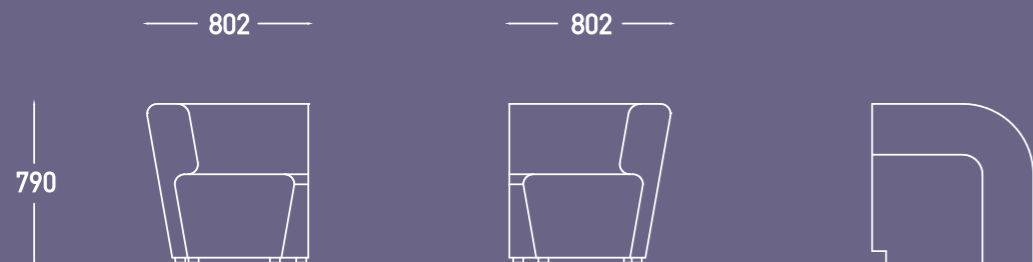

# N-ALLY

**NAL 29**



**NAL 30**

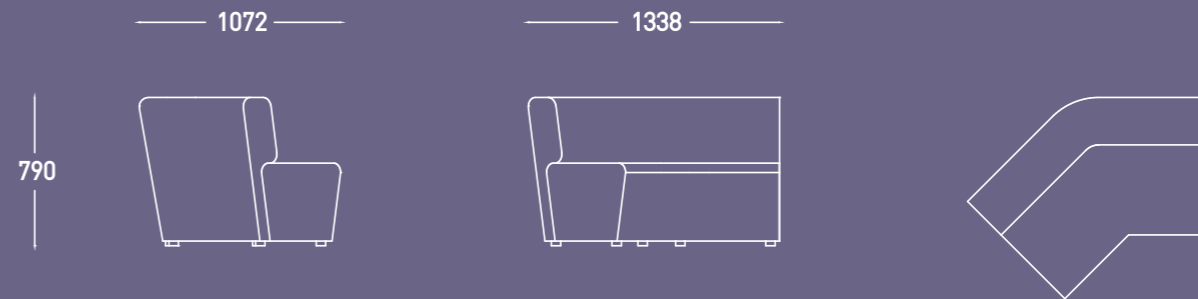

**NAL 31**

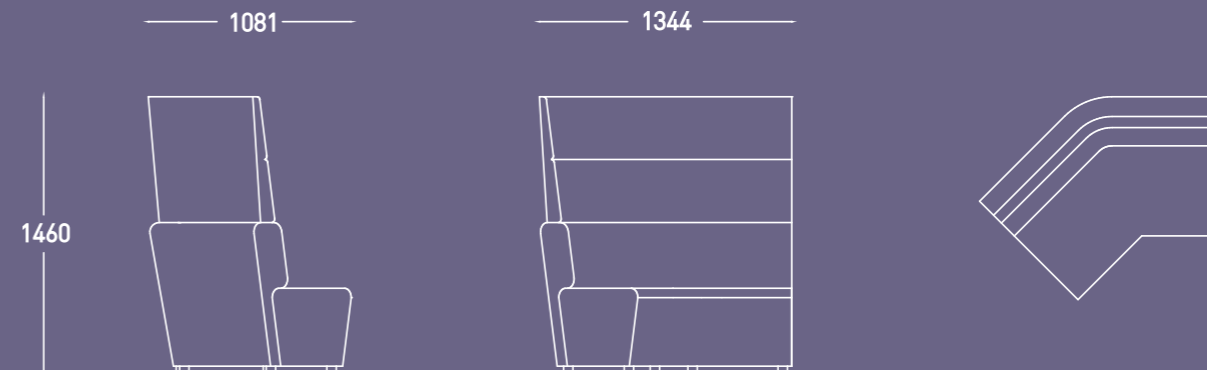



# N-ALLY

NAL 32

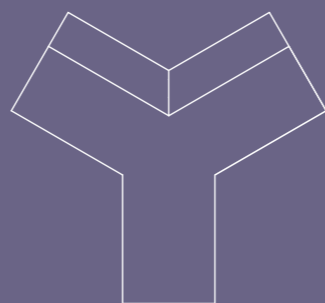
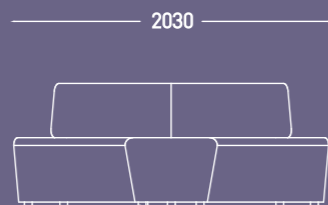
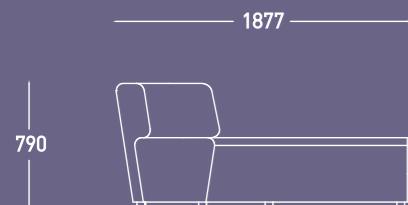

NAL 33

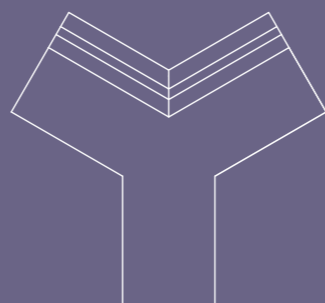
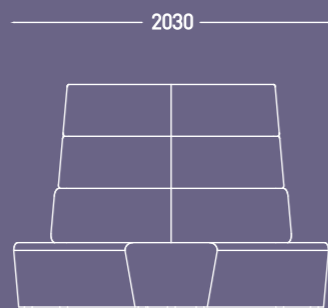
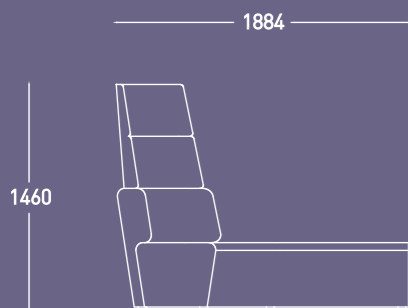



# N-ALLY

## NAL 34

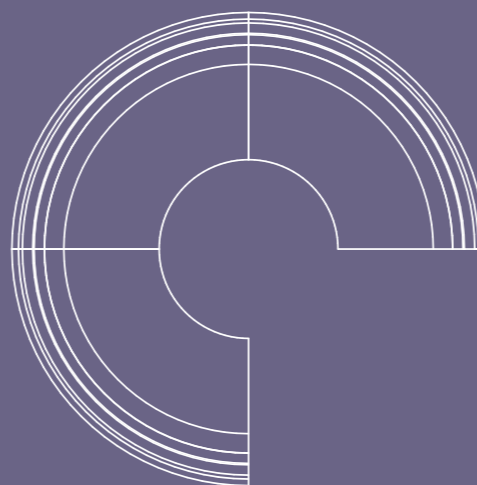
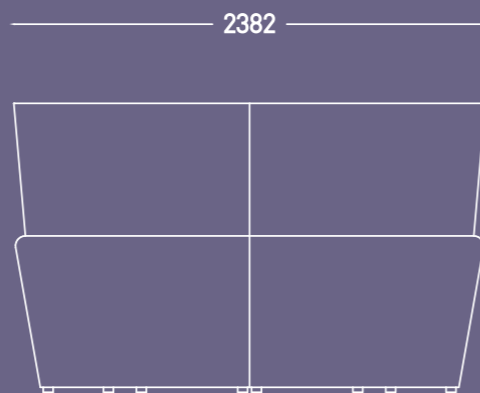
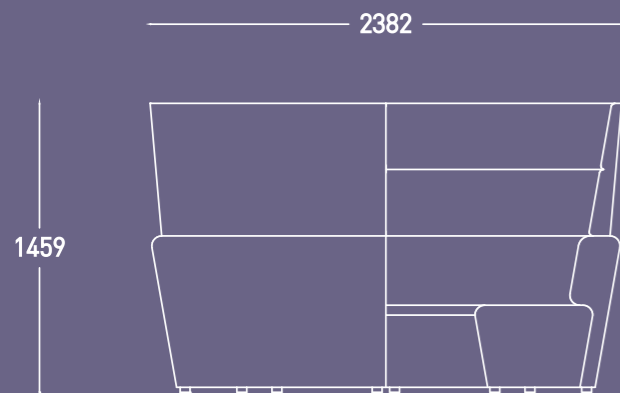

## NAL 35

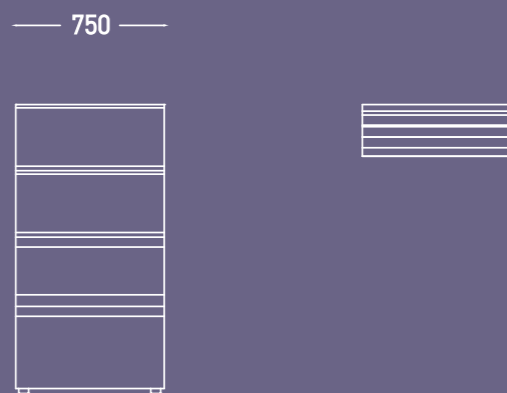
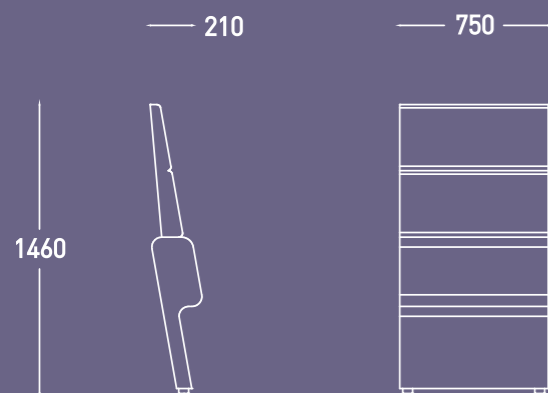



## Responsibility to our environment

- At 2020FD we have our own in house design team, this means that we can control all of the materials that are involved in the production of our furniture from the start. We look to use sustainable materials as much as we can.
- We think about the type of timber and foam that goes into our products. All of the timber we use is supplied by FSC labelled companies taking care of the world's forests. Any foam waste returns back to the foam converters to produce chip foam that we can and do also use.
- We use the latest CAD software to design and lay out our product shapes to make the best savings on materials as much as we can keeping material waste as tight as possible.
- Staying away from Land Fill is one of our main priorities at 2020. At 2020FD we have invested in a furnace which uses all of our timber waste as fuel to heat the water and factory giving us cleaner air and less Co2 emissions.
- We use a lot of fabric material at 2020 and although we nest our patterns the best way we can to produce the least waste possible we have off cuts, we help guide our clients to use materials that are natural and compostable.
- Our in house marketing produces PDF brochures and price list which is constantly updated. The amount of printing we produce is extremely minimal.
- Where we can we try to make deliveries the most economical way possible to use as less fuel as possible. We also offer electric vehicles to our sales team reducing transport emissions.

## CARE INSTRUCTIONS

### General Maintenance:

Vacuum regularly to remove dust and grit.

Clean spills and stains quickly to prevent them setting in.

If being used in a spill / stain-prone area specify a stain repellent finish or Scotchgard treatment (additional charges may apply)

For appearance retention we recommend regular professional cleaning to give your furniture a longer life.

### Natural Fabrics:

In addition to regular vacuuming, wool and other natural fibres can usually be cleaned using branded upholstery shampoo.

For a deeper clean, it's best that wool be dry cleaned, as over wetting can cause shrinkage and change in appearance.

Never apply bleach, ammonia, alkali or strong acids to wool upholstery.

### Synthetic Fabrics:

Vacuuming is the best regular maintenance, followed by speed of action to remove spills and stains rapidly as soon as they occur.

Most synthetic fabrics can be wiped down with a water-soaked damp cloth without fear of damaging the fibre or removing the colour. Stubborn stains can be removed with upholstery shampoo.

### Care of MFC / Laminates

You should only need to use a clean, damp, non-abrasive cotton cloth, and a mild liquid detergent or household cleaner. Rinse when clean with water. Do not use too much water, especially near edges, as water can cause them to swell. Dry the surface with a soft, clean, non-abrasive cotton cloth.

**2020**<sup>®</sup>  
FURNITURE DESIGN

BRIGADE HOUSE  
ALINGTON ROAD  
LITTLE BARFORD  
ST NEOTS  
PE19 6WG

TEL: 01480 700 050

E-MAIL: SALES@2020FURNITUREDESIGN.CO.UK

